

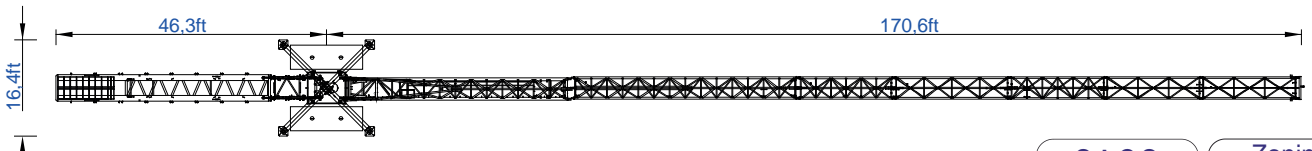

STF 5030

Data Sheet
Imperial

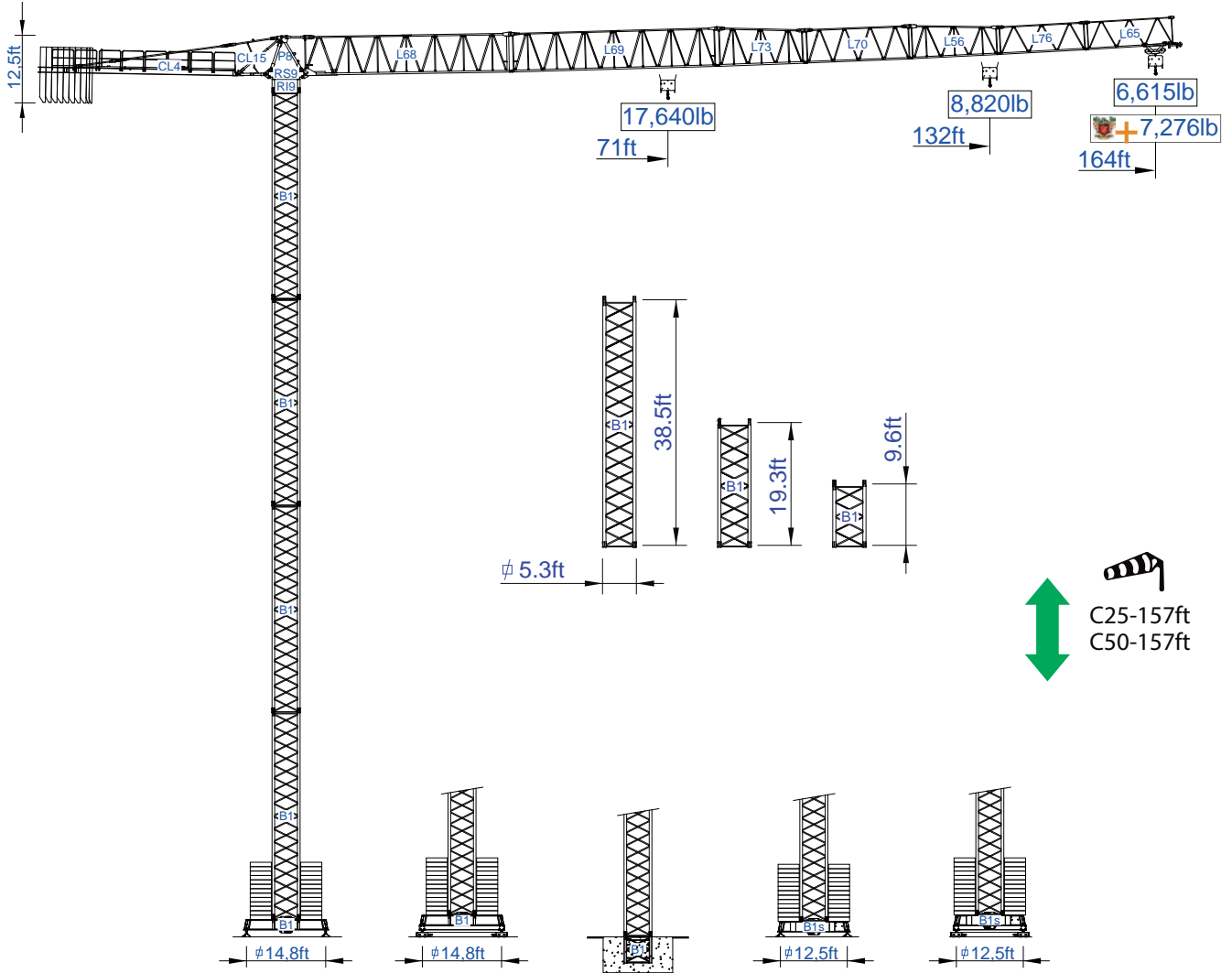

Headquarters

3620 S. 40th Street, Phoenix, AZ, 85040 USA
+1 (480) 993 3302

Factory

Zona Industrial de Canas de Senhorim - EN 234, 3525-040 Canas de Senhorim - Portugal
+351 232 673 530 sales@staffordtowercranes.com

www.staffordtowercranes.com



Empresa certificada no âmbito da Conceção, Fabrico e Serviço Pós-venda de Gruas Soima e componentes

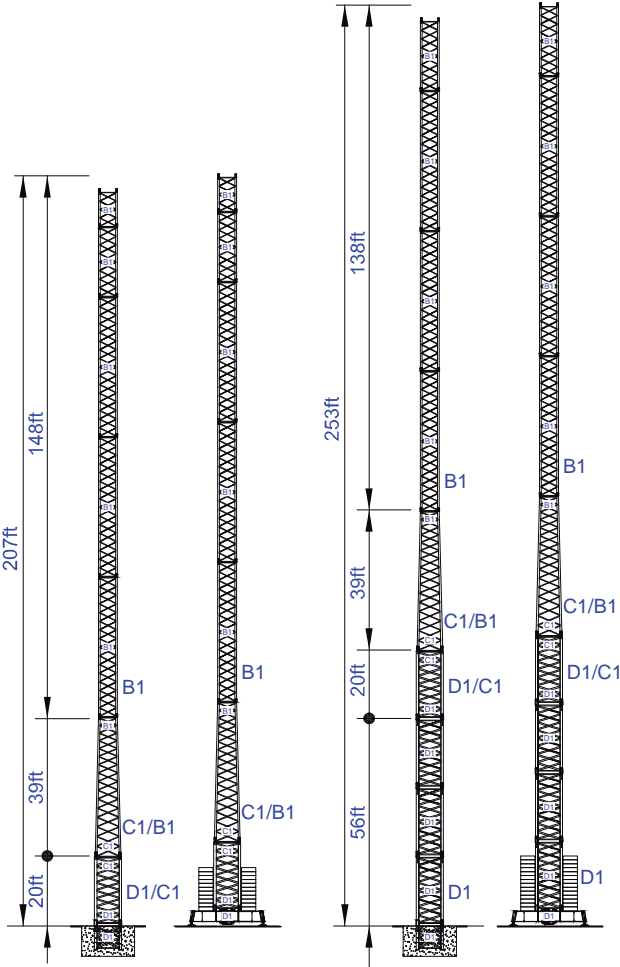
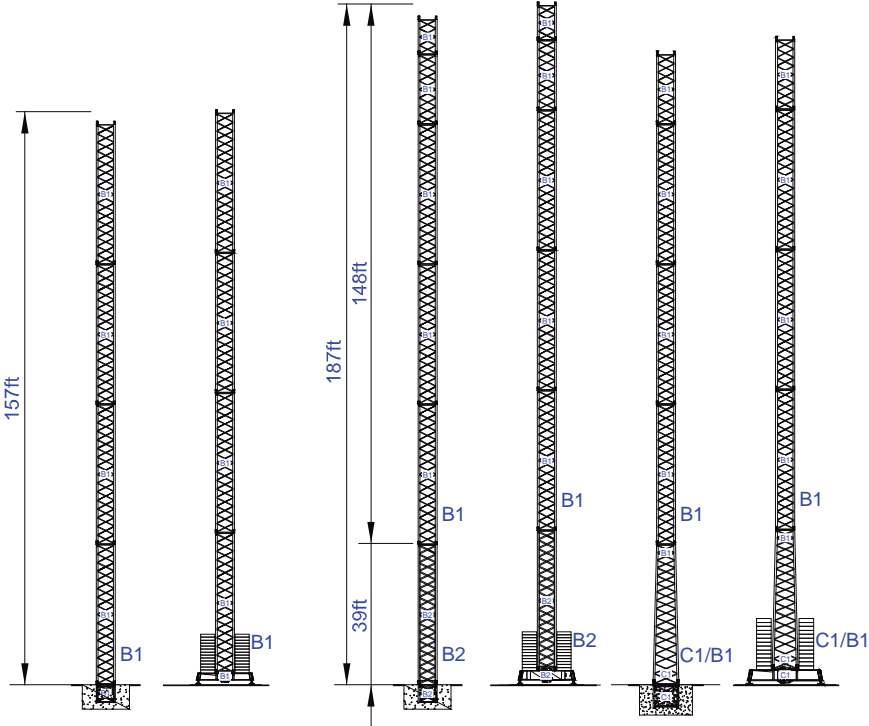

More options

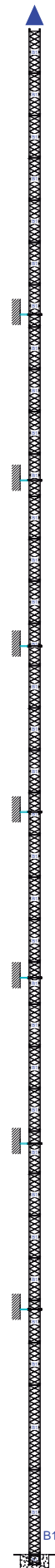
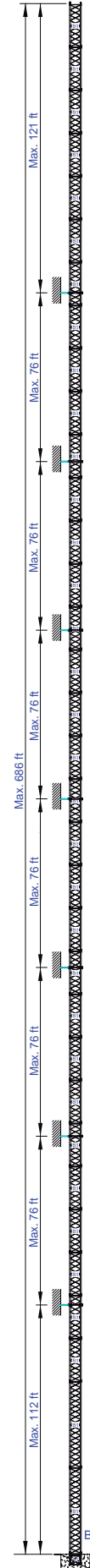
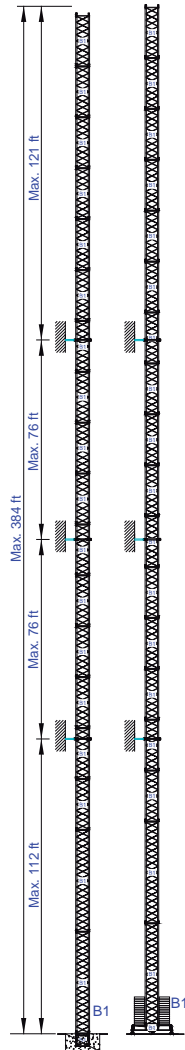
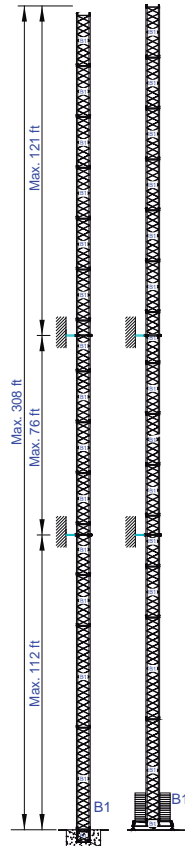
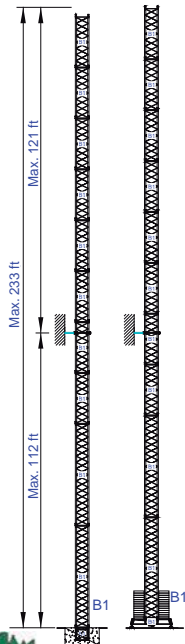
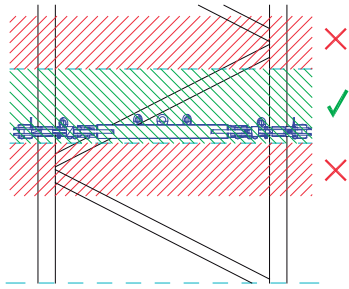
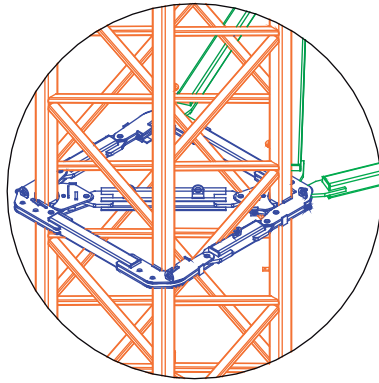

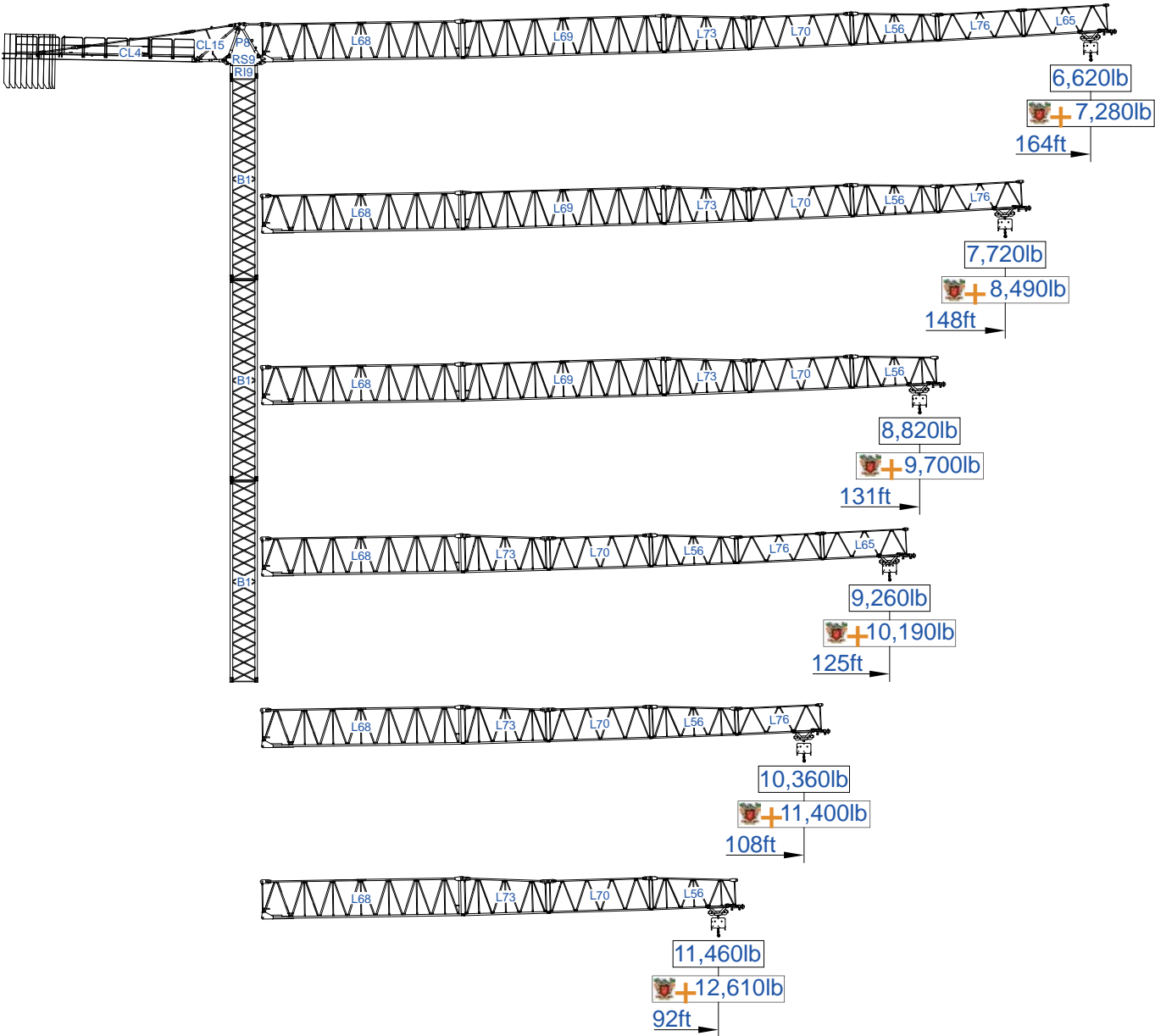











SACS

10%

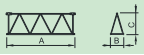
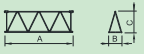
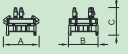

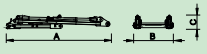
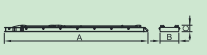

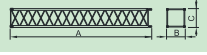
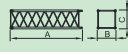

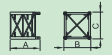
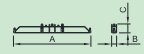
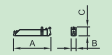
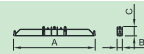
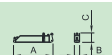
Diagram	Diagram	Icons		Columns											ft
		17,640lb	8,820lb	33	49	59	75	92	108	125	131	148	164		
164	39,683lb 8x4,409lb + 2x2,204lb	71,2	131,9	8,820	8,820	8,820	8,820	8,820	8,820	8,820	8,820	8,820	8,270	7,280	lb
				17,640	17,640	17,640	17,640	14,330	11,900	10,120	9,520	8,270	7,280		
148	39,683lb 8x4,409lb + 2x2,204lb	72,8	134,8	8,820	8,820	8,820	8,820	8,820	8,820	8,820	8,820	8,820	8,490		
				17,640	17,640	17,640	17,640	14,680	12,190	10,360	9,770	8,490			
131	35,274lb 7x4,409lb + 2x2,204lb	72,8	131,2	8,820	8,820	8,820	8,820	8,820	8,820	8,820	8,820	8,820			
				17,640	17,640	17,640	17,640	14,570	12,130	10,320	9,700				
125	28,660lb 6x4,409lb + 1x2,204lb	72,5	124,7	8,820	8,820	8,820	8,820	8,820	8,820	8,820	8,820				
				17,640	17,640	17,640	17,640	14,440	11,970	10,190					
108	26,455lb 5x4,409lb + 2x2,204lb	69,9	108,3	8,820	8,820	8,820	8,820	8,820	8,820						
				17,640	17,640	17,640	17,110	13,730	11,400						
92	22,046lb 4x4,409lb + 2x2,204lb	65,3	91,9	8,820	8,820	8,820	8,820	8,820							
				17,640	17,640	17,640	15,720	12,610							
		lb		Icons											





			A (ft)	B (ft)	C (ft)	lb (±5%)
Jib		L68	39.30	6.20	7.50	11,130
		L69	39.20	3.80	7.40	3,640
		L73	17.20	3.80	7.40	1,650
		L70	20.30	3.80	6.40	1,500
		L56	17.10	3.80	6.30	1,300
		L76	17.00	3.80	5.30	820
		L65	16.80	3.80	5.30	730
Head turntable		RS9 RI9	8.20	5.60	6.40	10,250
		P8	7.30	4.30	2.70	1,830
Counter-jib		CL15	11.20	4.30	1.30	1,320
		CL4	37.40	4.90	1.60	8,270
Counterweight		CP2	3.80	1.10	10.30	8x4,410 35,270
		CP3	3.80	0.50	10.30	2x2,200 4,410
Tower section / torre		B1	39.40	5.30	5.30	7,610
		B1	20.10	5.30	5.30	3,970
		B1	10.50	5.30	5.30	2,360
Climbing tower section		B1	10.50	6.00	6.00	2,430
		B1	5.80	5.20	5.20	1,430
Base Chassis		B1	21.70	1.60	3.40	4,830
			10.20	1.10	3.40	2x2,160 4,320
TOTAL						9,150
Base Chassis		B1s	18.40	1.60	3.40	3,970
			8.90	1.10	3.40	2x1,984 3,960
TOTAL						7,930

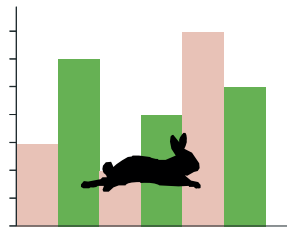

	
	0 a 1 r.p.m. 2x48 ft/lbf
	0 a 196 ft/min 5,5 kW
	0 a 32 ft/min 2x4 kW



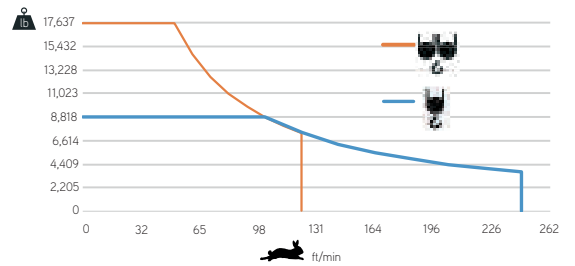

	
	0 a 246 ft/min 0 a 123 ft/min 22 kW



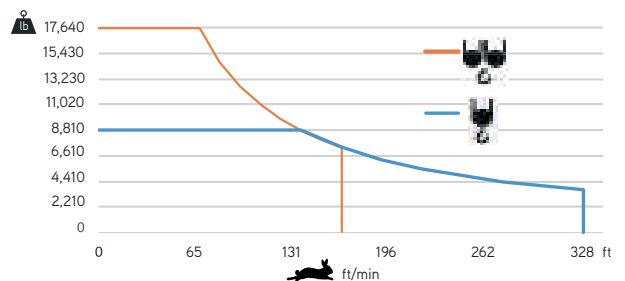

	48 kVA 400 V +- 5% (50/60 Hz)
--	----------------------------------

	
	0 a 330 ft/min 0 a 165 ft/min 30 kW



	58 kVA 400 V +- 5% (50/60 Hz)
--	----------------------------------

Max height of hoist

 (H)Max. 177ft More options
 (H)Max. 354ft 



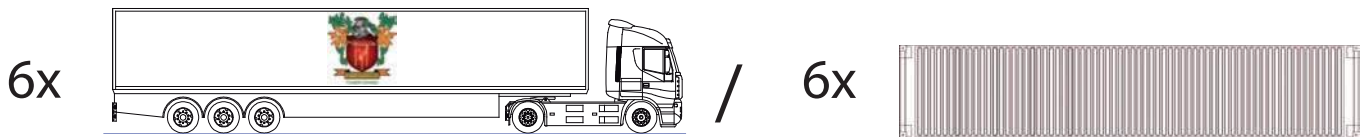
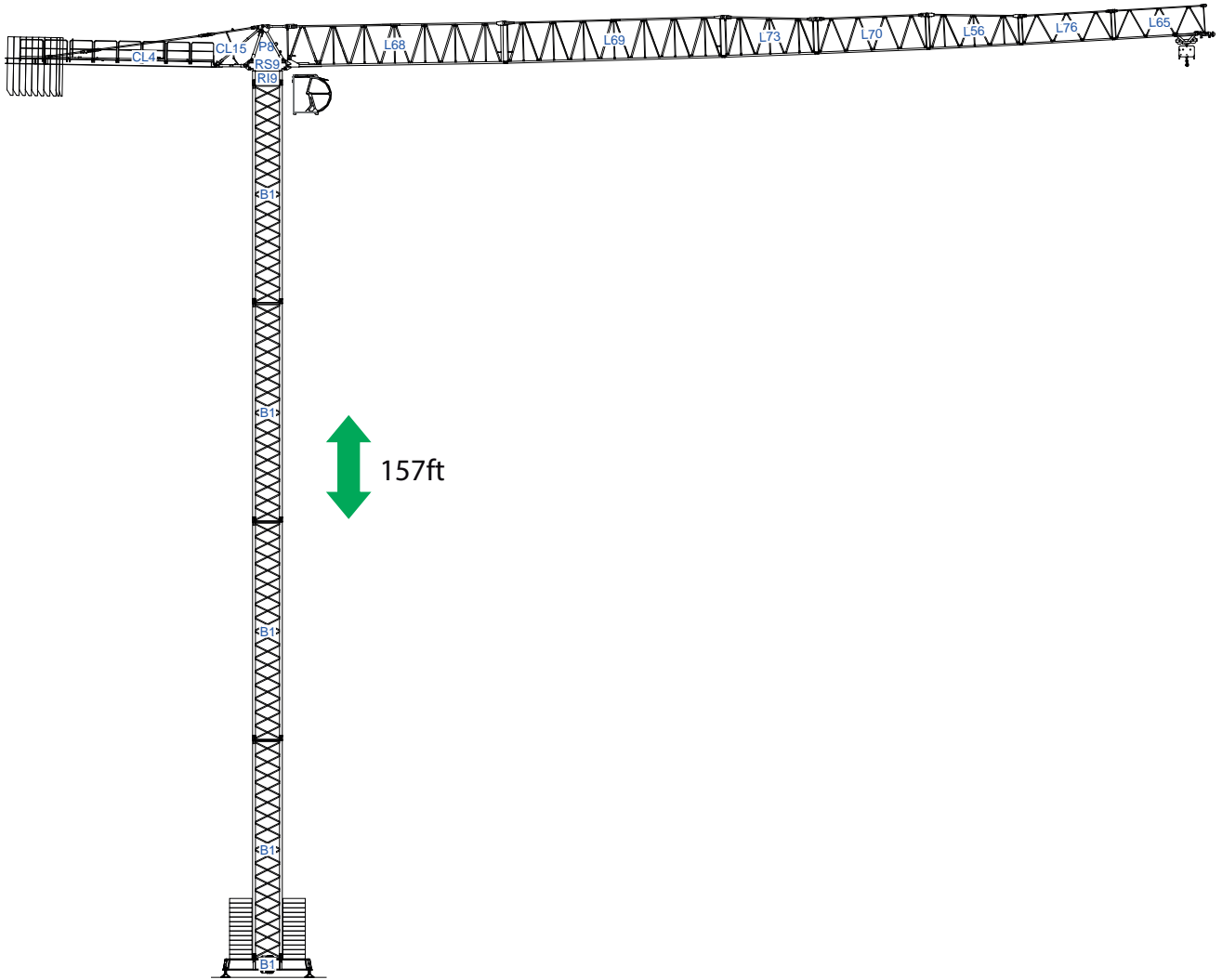

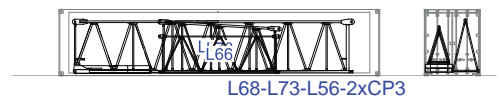
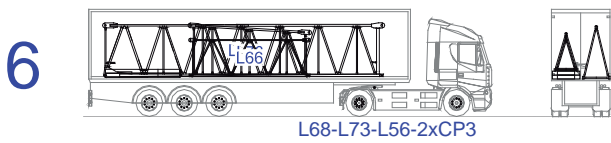
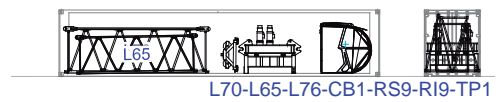
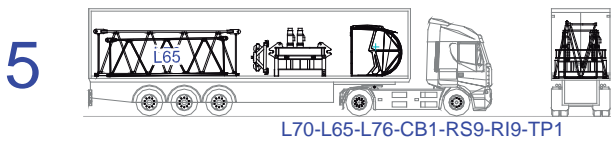
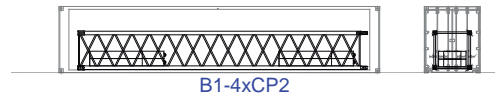
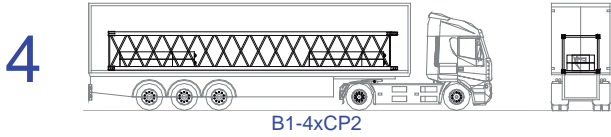
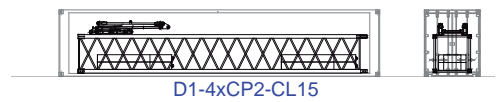
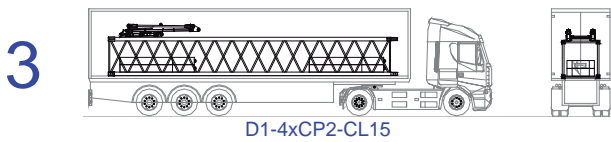
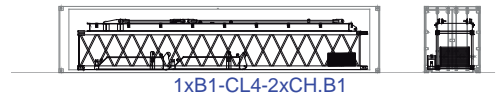
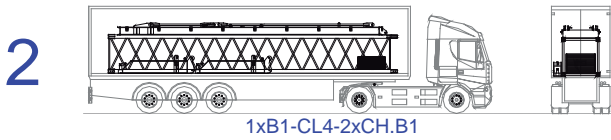
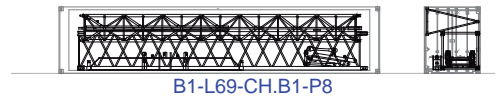
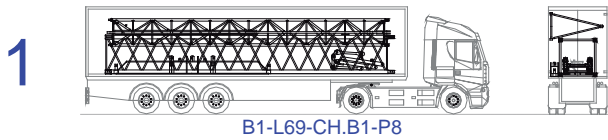



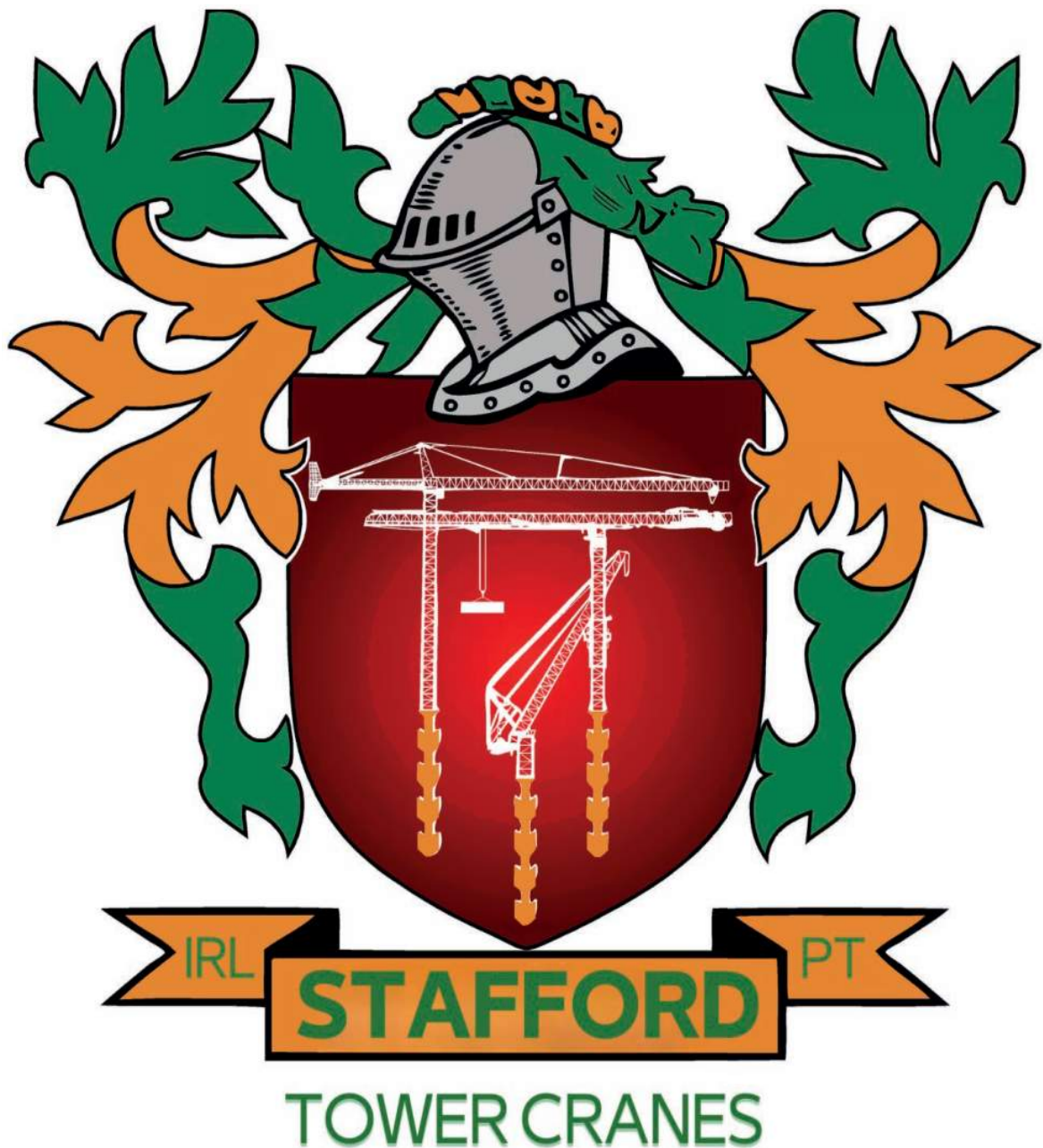

Headquarters

 3620 S. 40th Street , Phoenix , AZ, 85040 USA

 +1 (480) 993 3302

Factory

 Zona Industrial de Canas de Senhorim - EN 234, 3525-040 Canas de Senhorim - Portugal

 +351 232 673 530  sales@staffordtowercranes.com

 staffordtowercranes.com